

Processing Sinks

At Future Health Concepts, our Processing Sinks/Clean-up Counters are specifically designed to fit your facility's needs. All of our Processing Sinks & Pass-through Windows at FHC are **FULLY CUSTOMIZABLE** for individual requirements of the customer at an affordable price. The quality and design of our sink/window are ensured by its fully welded construction, and sleek stainless steel finish.

FHC Processing Sinks & Clean-up Counter Specs:

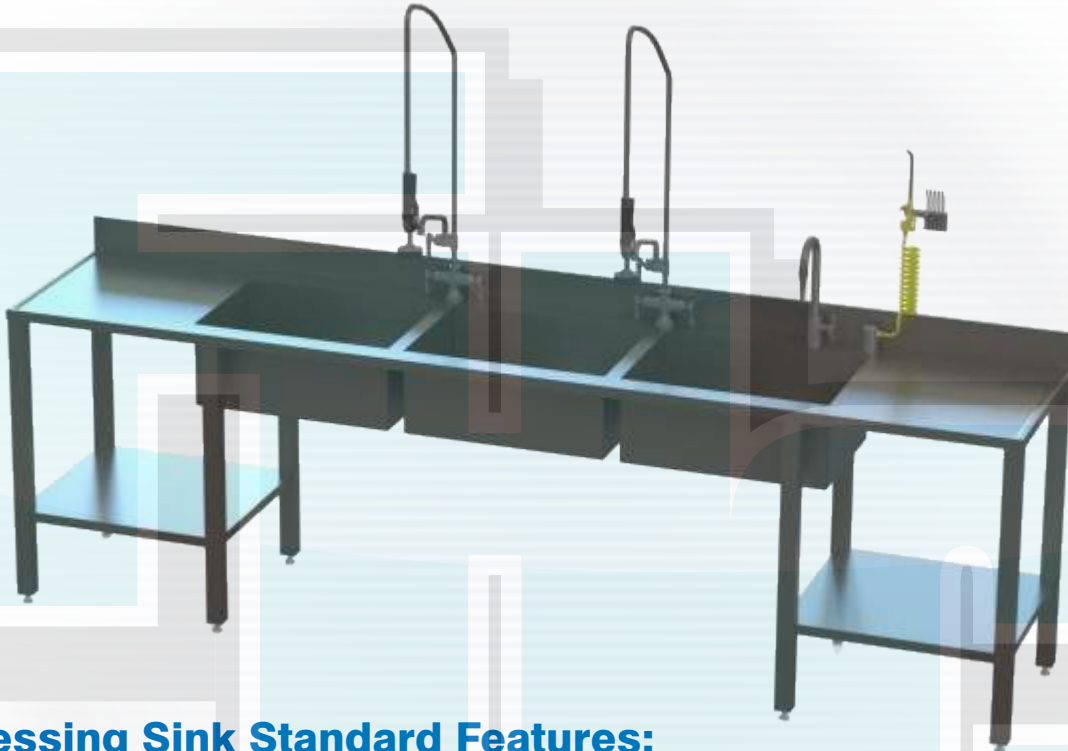

Processing Sink Standard Features:

- Fully-welded construction
- Sound-proofed reinforced tops
- Multiple layouts for individual requirements
- All sinks are manufactured to individual specifications
- Full CAD rendering of specific sink

Options:

- Hydraulic adjustable heights for ergonomics
- Full base unit underneath with any door, drawer or open shelf combination
- Pipe stand instead of base unit
- Multiple bowls in any combination
- Multiple faucet options including pre-rinse
- Air hose with 5 blowgun tips
- DI water
- Foot operated drains

Processing Sinks

Sample Processing Sinks:

Single Processing Sink



Double Processing Sink



Triple Processing Sink

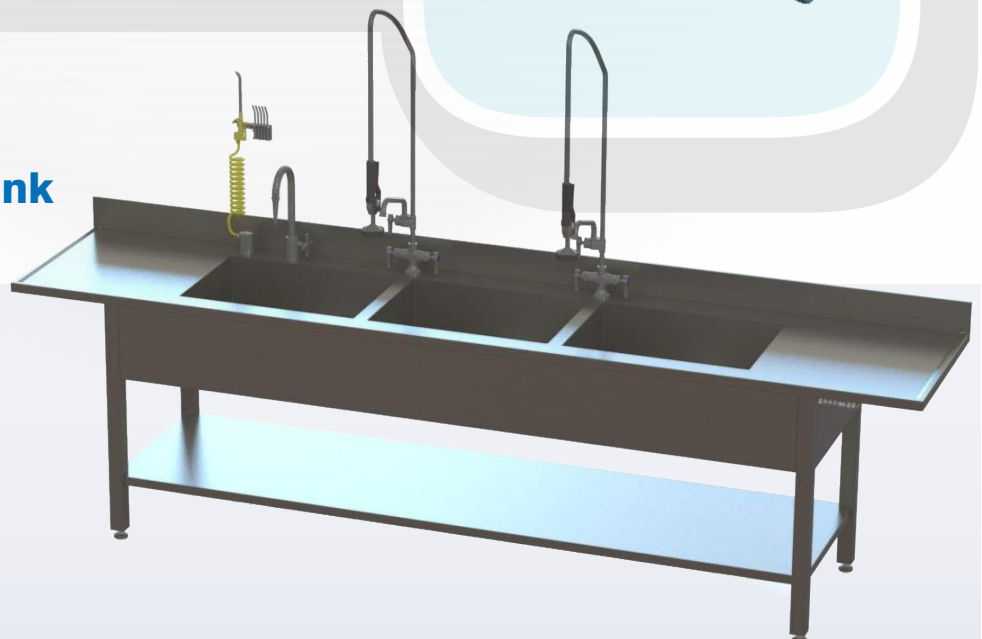

Processing Sinks

Adjustable Processing Sink Drawing Example:

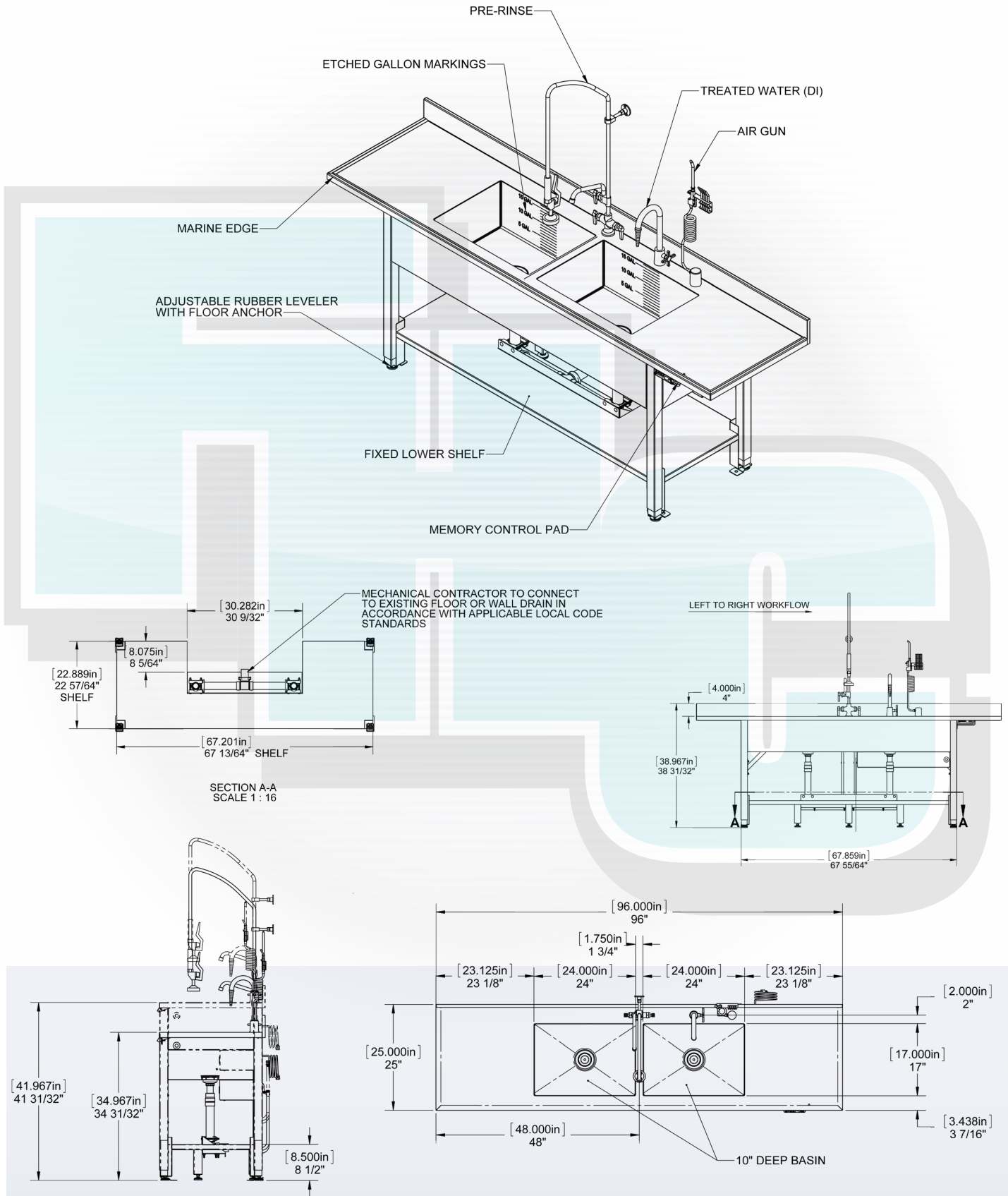

Processing Sinks

Triple Processing Sink Drawing Example:

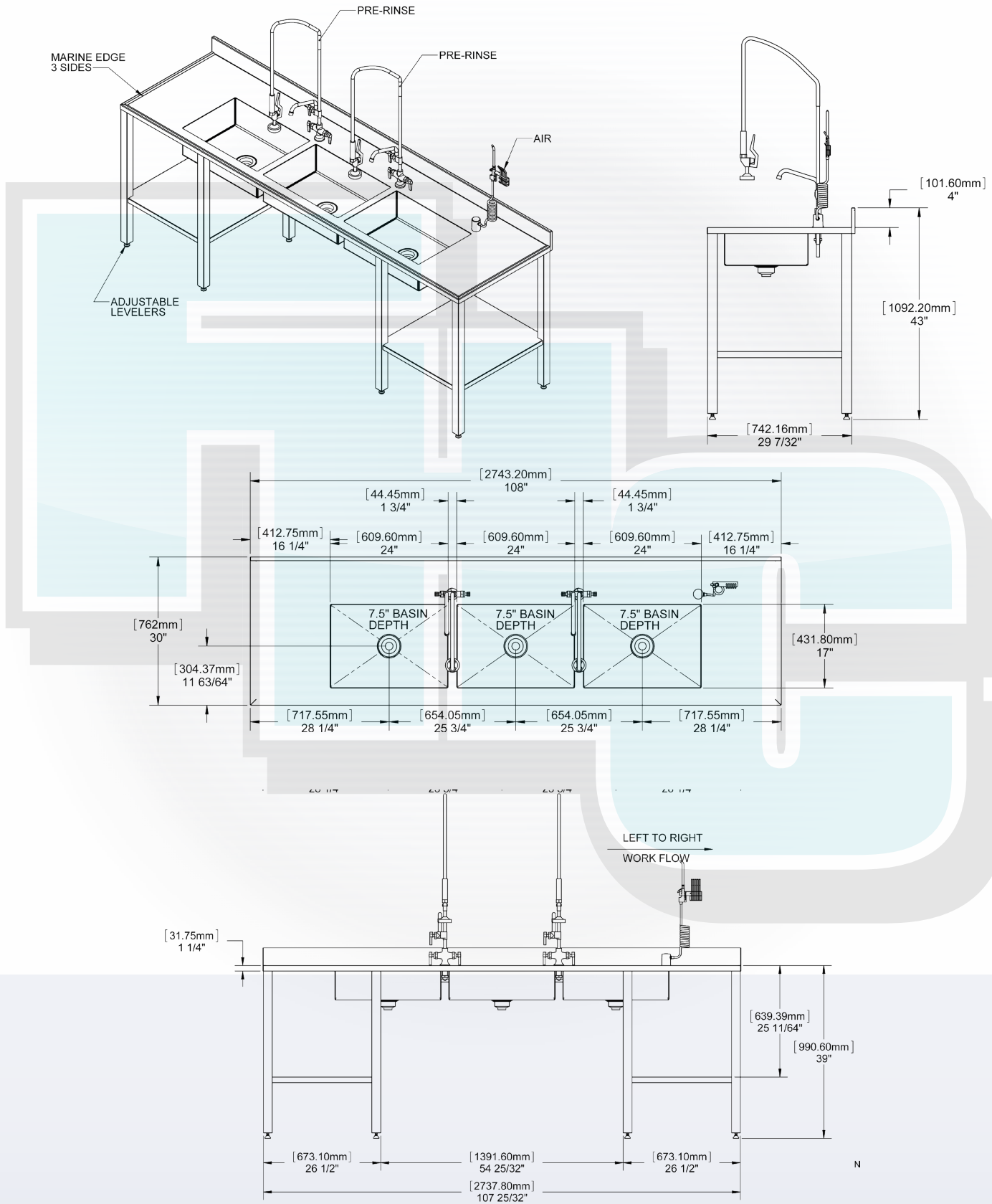

Processing Sinks

Double Processing Sink Drawing Example:

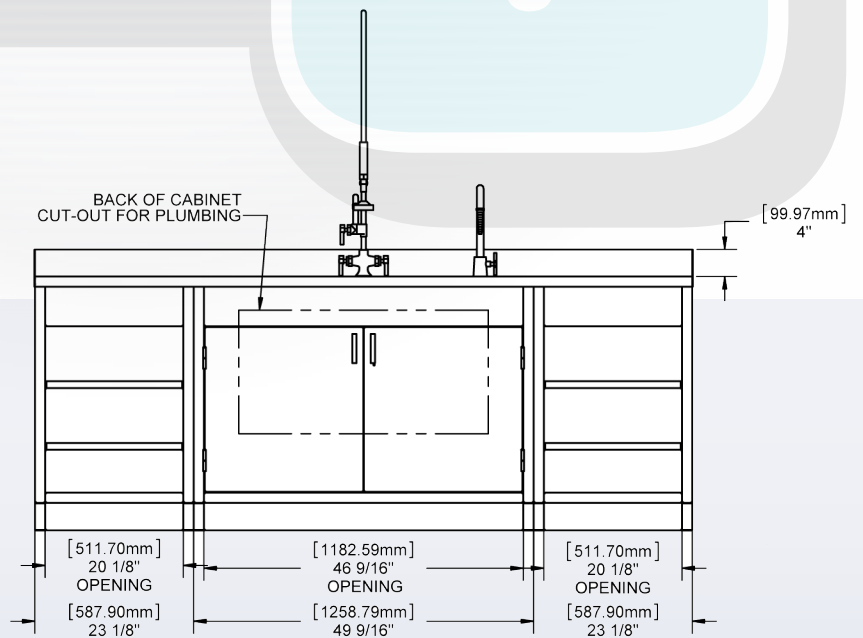
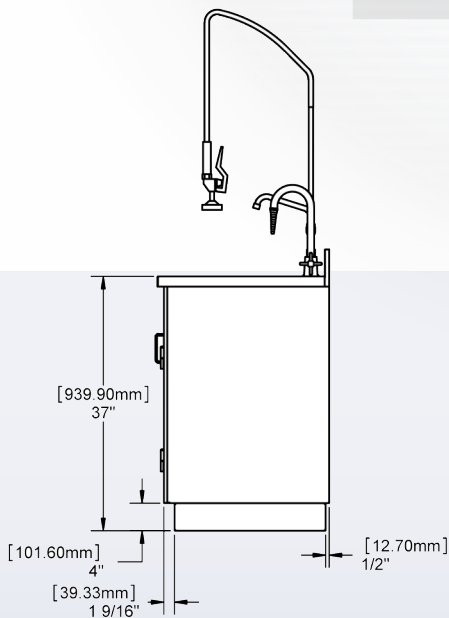
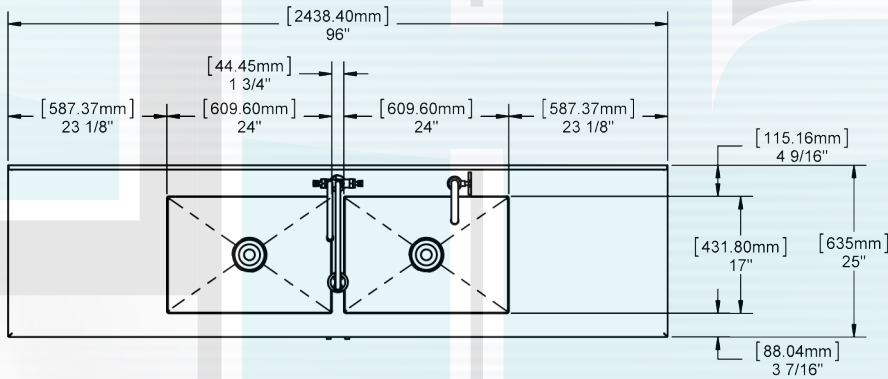
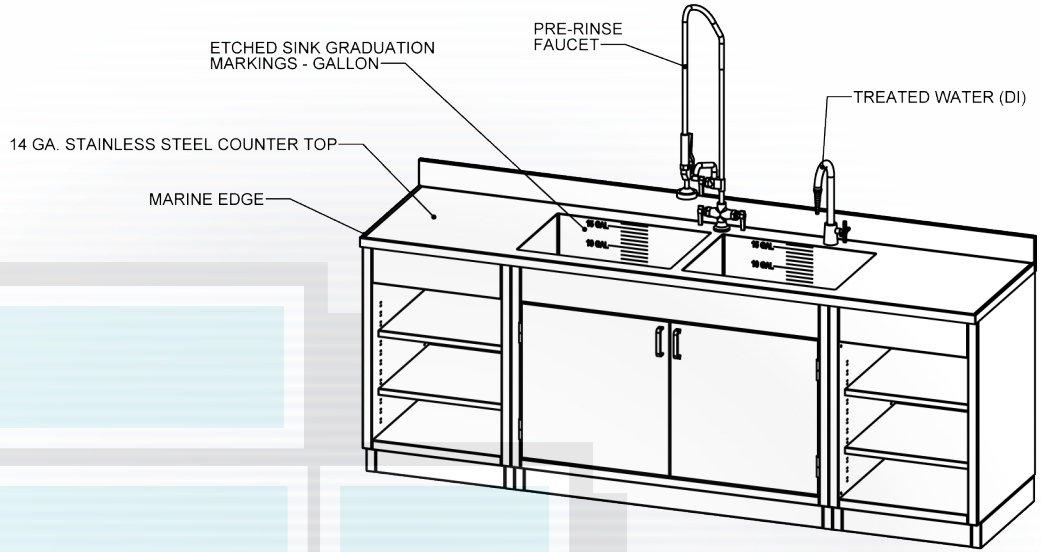

Processing Sinks

Single Processing Sink Drawing Example:

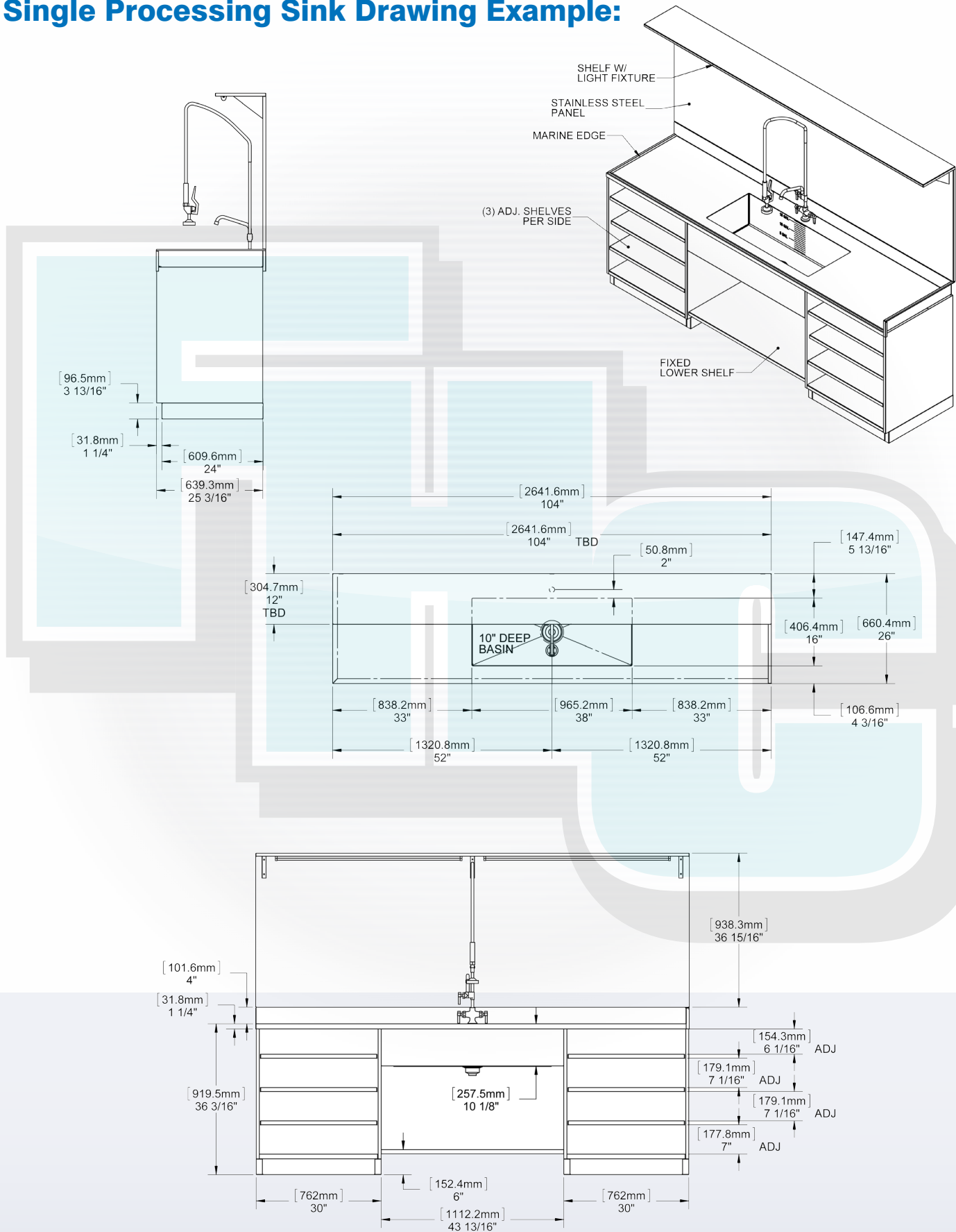

Processing Sinks

Processing Sink Accessories:

Pre-Rinse & Faucet Combo

Our deck mounted pre-rinse & faucet combination option provides convenience and efficiency.

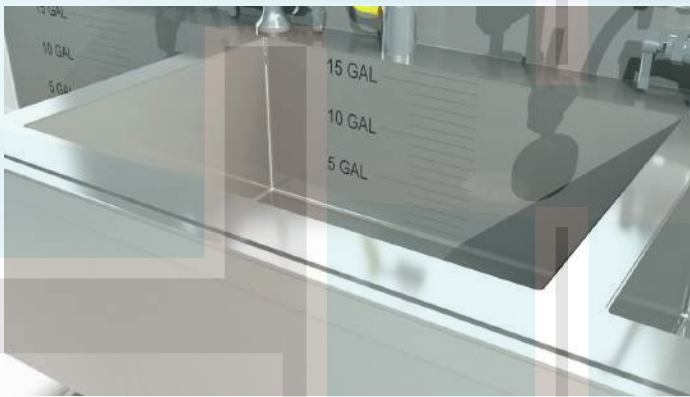

Etched Gallon Markers

With our optional etched gallon markers in the sink, correct mixtures are even easier to maintain.

Drain Lever Handle

A lever handle for the drain, located under the sink, ensures maximum functionality for draining.



Processing Sinks

Processing Sink Accessories:

Air & Water Pistols

The air and water pistol option are essential for thorough cleaning requirements.

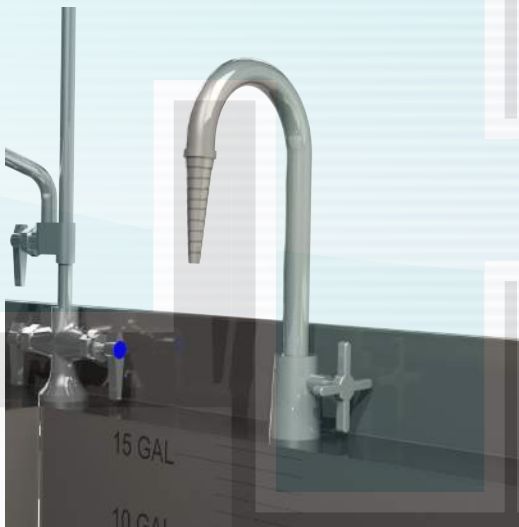
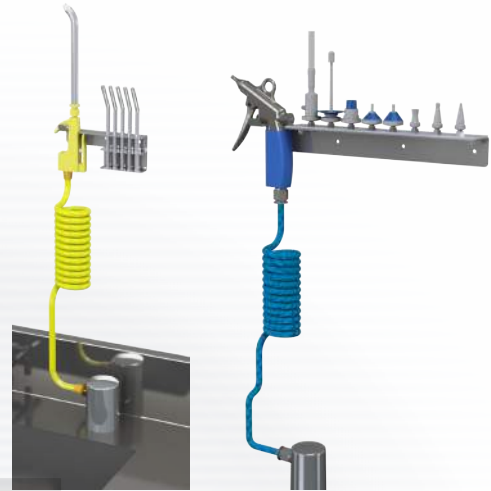

RO Water

RO water completes requirements for the manual cleaning process.

4" Back Splash

Our 4" back splash option gives consumers the most ideal working surface.

